

PROTEUS (No Scan Required)

BACKS

AIREZ Custom Back (MACB-B)

CUSHIONS

AIREZ Custom Seat Cushion (MACSC-B)

Auxafoam Custom Seat Cushion (MCSC-B)

PROVIDER INFORMATION

Account #: _____

Company Name: _____ Contact Name: _____

Phone Number: _____ Email: _____

Mailing Address: _____

City: _____ State: _____ ZIP: _____

Shipping Address: _____

City: _____ State: _____ ZIP: _____

Our seating products must be installed by Matrix Certified Providers and will not be drop shipped to end users.

CLIENT INFORMATION

Client First and Last Name: _____

Client Height: _____ **Client Weight*:** _____

Wheelchair Make: _____ Model: _____

Frame Width: _____ **Frame Depth:** _____

Seat Base Type: Solid Pan Sling Seat

Special Considerations*: High Tone Spasticity

Bold sections indicate required fields.

* Upgrades may be required for clients whose weight exceeds 250 LBS or present with severe spasticity or extensor tone.

MEASUREMENTS

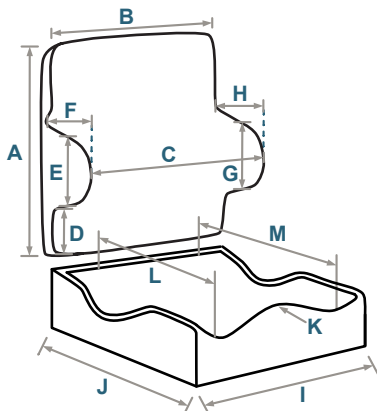

Back Specifications		Value (in.)
A	Back Height	
B	Back Width	
C	Inside Lateral Width	
D	Lateral Start ___" from Bottom	
E	Patient RIGHT Lateral Height	
F	Patient RIGHT Lateral Depth	
G	Patient LEFT Lateral Height	
H	Patient LEFT Lateral Depth	

Seat Specifications		Value (in.)
I	Seat Width	
J	Seat Depth	
K	Pommel Height (if any)	
L	Patient RIGHT Leg Length (if asymmetrical)	
M	Patient LEFT Leg Length (if asymmetrical)	

Custom Proteus Backs

(E2617)

Proteus

Matrix AIREZ Custom Back (MACB-B)

\$3625

For maximum airflow and the lightest weight with strength and rigidity.

Standard configuration includes: an ultra-lightweight adjustable back, therapeutic premium 3D mesh liner, and a breathable spacer fabric cover.

HARDWARE OPTIONS (SELECT ONE)

- Ultra lightweight mounting hardware, mounting width:
 - Frame width: _____** " (VTMH-B)
- Radian 360 mounting hardware, mounting width:
 - Frame width: _____** " (RAD-B)
 - Add additional Radian 360 of same size (RAD-EX) \$595
- Power Wheelchair Adapter (PWA-B)
- Power Wheelchair Bundle (PWB-B)
- Omit Hardware (RAD-O)

HARDWARE MOUNTING ACCESSORIES

- Cane Claw Hardware - Round Mount (R360-CC)
- Surface Mount Hardware - Flat Mount (R360-SM)
- Quick Release Hardware Upgrade (R360-QR-B)
- Additional Pair of Mounting Clamps
 - Cane Claw (R360-EC) \$230
 - Surface (R360-ES) \$230

OPTIONAL - ALTERNATIVE BACK COVER

- Replace with Dartex Style Cover (CVRBU-DAR-B)

OPTIONAL - ADDITIONAL BACK COVERS

- Additional Spacer Fabric Cover (CVRB-SF) \$345
- Additional Dartex Style Cover (CVRB-DAR) \$550
- Additional Incontinence-proof exterior cover (CVRB-IP) \$250
- Privacy Flap (MCB-PF) \$150

OPTIONAL - BACK ACCESSORIES

- Universal Headrest Mount (CFI-HR-B)
 - Omit installation (CFI-O)
- Accessory Mounting Rails (MCB-IM-B)
 - Shoulder Harness Guides (MCB-SHG-B)
 - Omit installation (MCB-O)

Proteus: Custom Backs (E2617) + Custom Seat Cushions (E2609)



Custom Proteus Cushions

(E2609)

Proteus

Matrix AIREZ Custom Seat Cushion **(MACSC-B)**

\$2750

Includes a custom-molded AIREZ cushion and breathable spacer fabric cover.

OR

AUXAFUAM

Matrix Custom Seat Cushion **(MCSC-B)**

\$2750

Includes a custom-molded Auxafoam cushion, breathable spacer fabric cover, and an integrated incontinence-proof interior cover.

WHEELCHAIR SEAT SPECIFICATIONS (SELECT ONE)

Seat Base Type: Solid Pan Sling Seat

OPTIONAL - ALTERNATIVE SEAT COVER

Replace with Dartex Style Cover (CVRSU-DAR-B)

OPTIONAL - ADDITIONAL SEAT COVERS

- | | | |
|--|------------|-------|
| <input type="checkbox"/> Spacer Fabric | (CVRS-SF) | \$200 |
| <input type="checkbox"/> Dartex Style (Smoother Skin Contact) | (CVRS-DAR) | \$295 |
| <input type="checkbox"/> Incontinence-proof interior cover with zip | (CVRSI-IP) | \$250 |
| <input type="checkbox"/> Incontinence-proof exterior cover | (CVRSE-IP) | \$250 |

OPTIONAL - SEAT ACCESSORIES

- | | | |
|--|----------|-------|
| <input type="checkbox"/> Integrated Sling Seat Mounting Platform | (SSMP) | \$395 |
| <input type="checkbox"/> Seat Positioning Tray | (SC-SPT) | \$350 |

Additional Info

ADDITIONAL COMMENTS OR INSTRUCTIONS

